

DC88X
DOUBLE CYLINDER
E1330X - E1430X - E1530X



DOUBLE CYLINDER

E1330X - E1430X - E1530X



PNEUMATIC
TAKEDOWN

SIMPLIFIED
SHELL

SINGLE-MAGNET
SELECTION

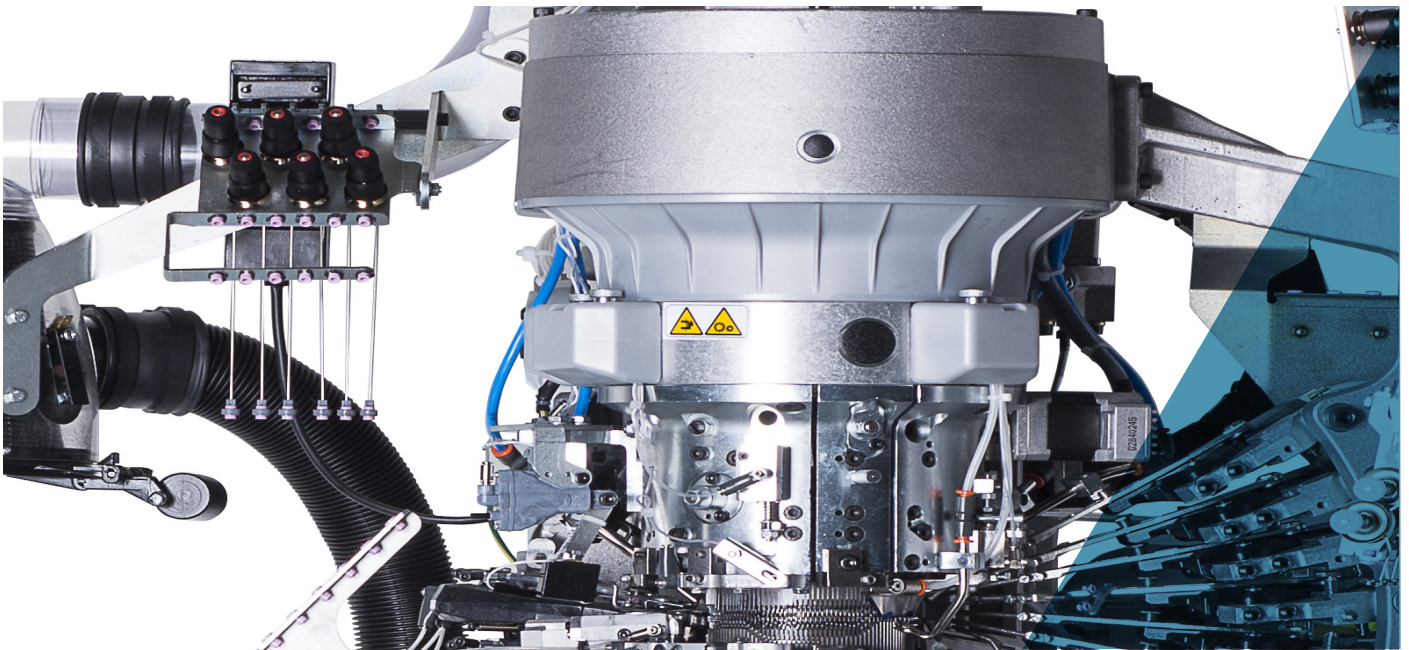

All images in this brochure are indicative and not binding.

DOUBLE CYLINDER

E1330X - E1430X - E1530X

Double cylinder 2 feeds machine for the production of men's, women's and children's socks in ribs, plain knit, links and links jacquard. Needle-needle single-magnet selection for different rib, links patterns and links jacquard. Tuck knitting option on first feed of lower cylinder. Brushless motor incorporated in the column with variable heel and toe reciprocating motion. 2 selection points instead of pickers and needle droppers. Electronic size control by automatic adjustment of the stitch. Available in 3" 1/2, 3" 3/4 and 4" diameters and gauge from 7 to 22.

- Needle-needle single-magnet selection instead of pickers and needle droppers and links drums for different rib and links patterns.
- Simplified shell/skirt with less mobile cams
- Takedown with electronic control and size self adjustment
- Stitch cams with independent stepper motors
- Electronic full control of yarnfingers and of all functions
- Easier sinkers maintenance thanks to the rotating knitting head

MACHINE DIMENSIONS



Length 90 cm + yarn creel 32 cm
Depth 104 cm + yarn creel 69 cm
Height 260 cm

MACHINE WEIGHT



Machine ca. 350 Kg
Yarn creel ca. 30 Kg

NOTE:

All data relating to outer appearance, performance, dimensions and weight are just as an indication.

DOUBLE CYLINDER

E1330X - E1430X - E1530X

TECHNICAL DATA

MODEL	CYLINDER DIAMETER	GAUGE	NEEDLE THICKNESS
E1330X	3"1/2	from 9 to 22	0,5 - 0,6 - 0,7 mm
E1430X	3"3/4	from 9 to 22	0,5 - 0,6 - 0,7 mm
E1530X	4"	from 7 to 22	0,5 - 0,6 - 0,7 - 0,9 mm

Above data are indicative and not binding.

STANDARD DEVICES

- Needle-needle single-magnet electronic selection system;
- Sock downtake with downwards movement control;
- Automatic turning device;
- Multi-stiffening by means of stepper motor;
- High heel by means of single-magnetic selection;
- Sinker cap with internal lubrication;
- 6 pneumatic yarnfingers;
- 4-rod take-up device;
- Suction valve controlled with stepper motor;
- Tail knitting at the start of the sock;

OPTIONAL DEVICES

- Fan
- Picot welt
- Size electronic control
- Split device
- Pneumatic yarnfinger number 7
- First yarnfinger positioning at feeds 5,6 and 7
- Second yarnfinger positioning at feeds 2,3 and 4
- Lycra plating
- Bare Lycra
- 6-rod take-up device
- Yarn brake discs opener 1 and 2
- Prearrangement for YoYo feeder
- Prearrangement for LGL feeder
- Spyder sensors
- Cassefiles mechanical sensors
- Knots electric sensors
- Ethernet board
- Patterned shadow stripe knit
- Open-work

SUITABLE YARNS

The machine is designed to be used with the following yarns

- Natural fibers
- Synthetic yarn
- Elastic yarn

POSSIBLE KNITTING

The standard machine can perform the following knittings

- Plain knit
- Rib
- Links
- Links Jacquard
- Tuck stitch on first feed on lower cylinder

DOUBLE CYLINDER

E1330X - E1430X - E1530X



NUMBER OF COLORS

Number of colors	In jacquard 2 colors on the same course Up to 5 colors on first feed Up to 3 colors on second feed
------------------	--

PERFORMANCES

GAUGE	4" CYLINDER DIAMETER
KNITTING FEATURES	14 (needle thickness 0.7)
	LINKS = 320 Rpm
	Rib and plain knit = 360 Rpm
	Reciprocated motion = 340 Rpm
	Tuck stitch = 260 Rpm
	Float stitch reciprocated motion = 260
	Jacquard = 260 Rpm

Above data are indicative and not binding.

GAUGE

		GAUGE															
Model	ø	6	7	8	9	10	11	12	13	14	15	16	17	18	20	22	
1330X	3"1/2				96 100 104	108 112	116 120 124	128 132 136	140 144 148	152 156	160 164 168	172 176 180	184 188 192	196 200	216 220 224	240	
		Needle thickness 0.7															
		Needle thickness 0.6															
		Needle thickness 0.5															

		GAUGE															
Model	ø	6	7	8	9	10	11	12	13	14	15	16	17	18	20	22	
1430X	3"3/4				104 108	112 116 120	124 128 132	136 140 144	148 152 156	160 164 168	172 176 180	184 188 192	196 200 204	208 212 216	232 236 240		
		Needle thickness 0.7															
		Needle thickness 0.6															
		Needle thickness 0.5															

		GAUGE															
Model	ø	6	7	8	9	10	11	12	13	14	15	16	17	18	20	22	
1530X	4"	76 80	84 88 92	96 100 104	108 112 116	120 124 128	132 136 140 144	148 152 156	160 164 168	172 176 180	184 188 192	196 200 204	208 212 216	220 224 228 232	248 252 256		
		Needle thickness 0.9															
		Needle thickness 0.7															
		Needle thickness 0.6												Needle thickness 0.5			

Above data are indicative and not binding.

DISCLAIMER:

For gauges lower or higher than those in the chart, their maximum speed must be reduced by 10-15%. Should you use staple fiber, maximum speed has to be detected each time according to the yarn and the item to be produced. For jacquard and Links jacquard, maximum speed has to be detected each time according to the pattern.

Lonati is recommending needles from
GROZ-BECKERT®

DOUBLE CYLINDER

E1330X - E1430X - E1530X

NOISE LEVEL

Machine average noise level, suction included LpA=81.9 dB LwA=99 db

LUBRICANTS

Average consumption for 100 dozens= 330 gr. Lonati recommends: Kluber Madol 183 Supreme

GREASE

For seals, bearing etc Lonati recommends: Damping grease Nyogel 774F

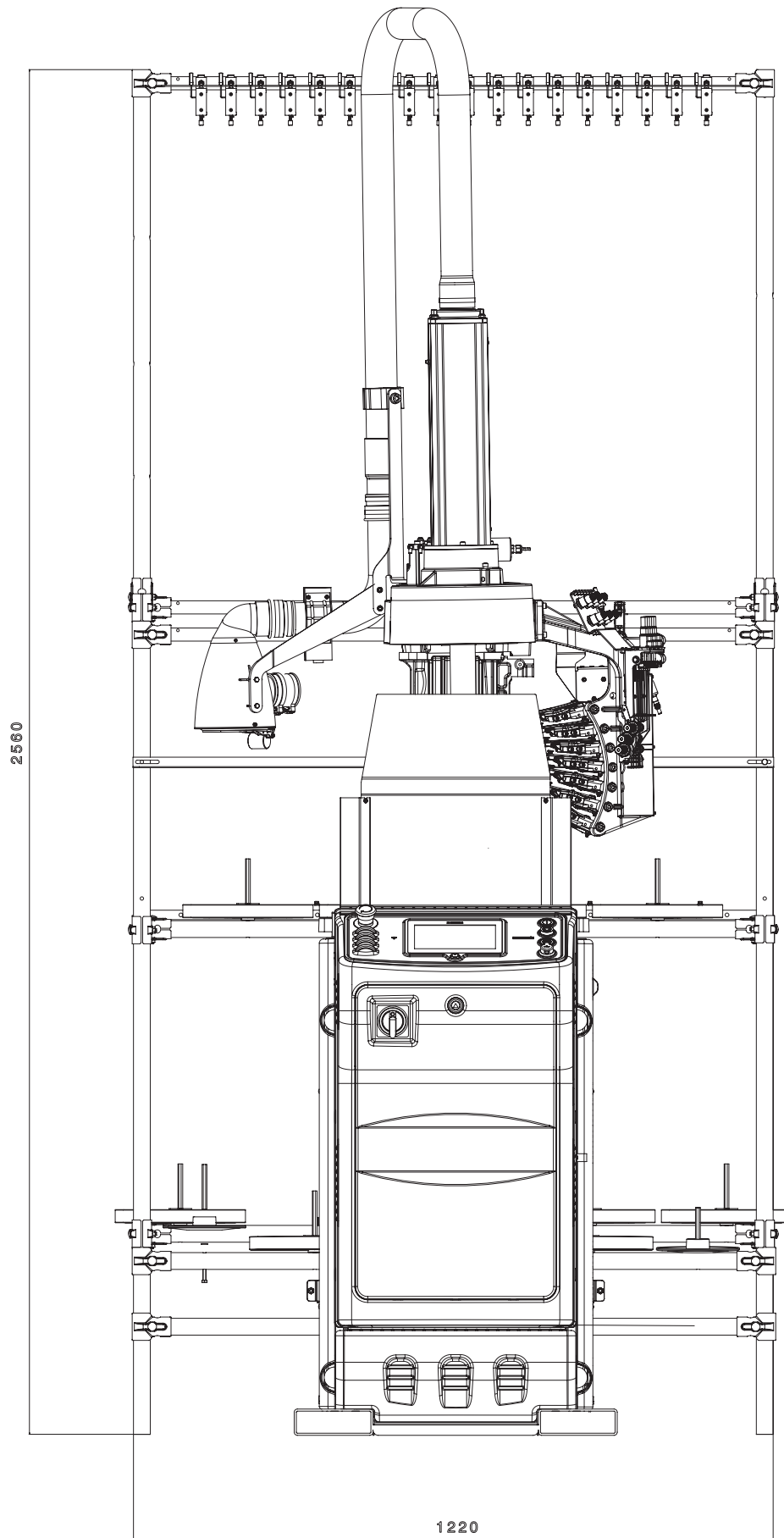

FRONT VIEW

Machine dimensions + 16 positions yarn creel.

NOTE:

The picture may show fittings and equipment that are supplied on demand and not.

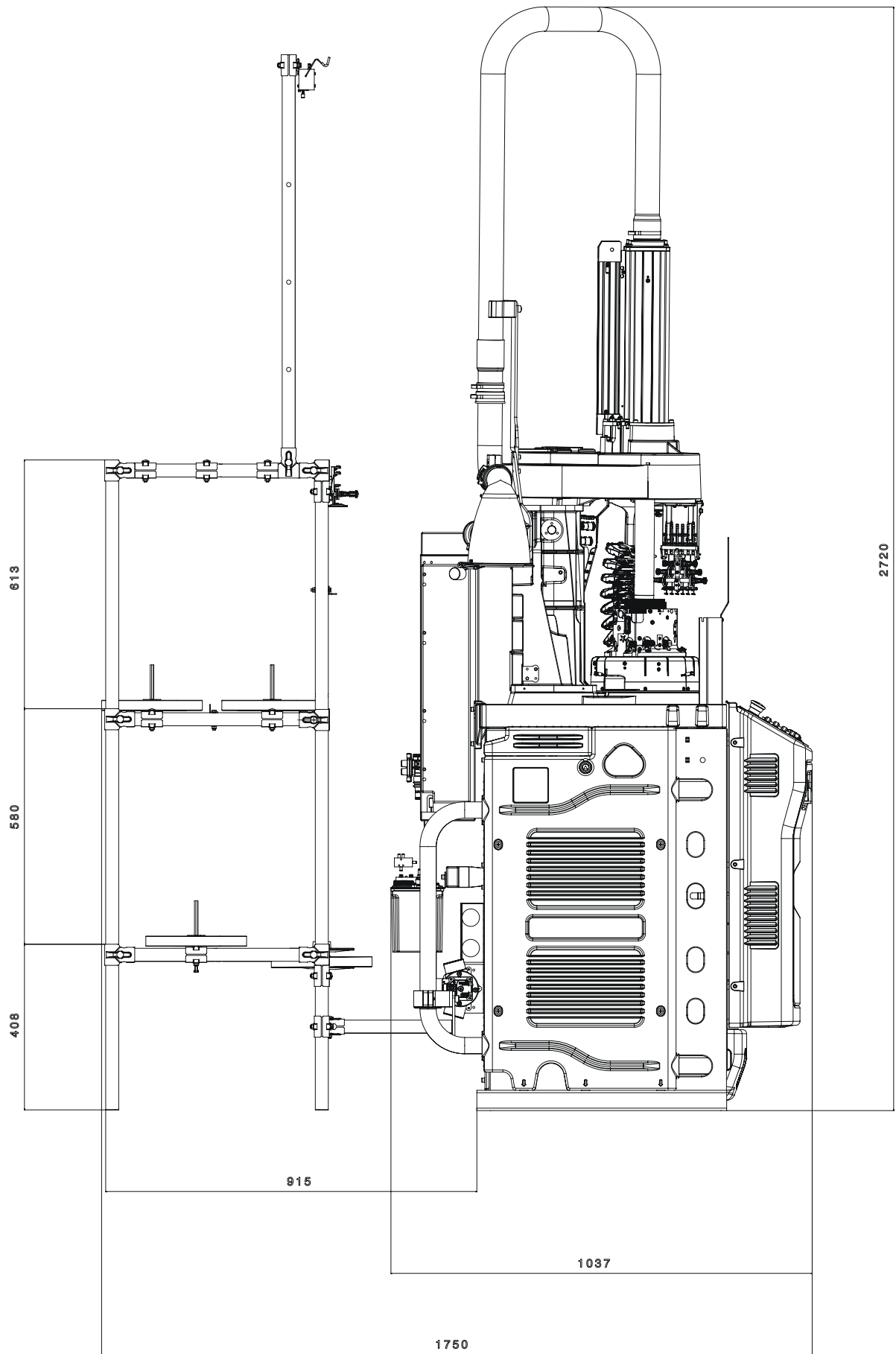

SIDE VIEW

Machine dimensions + 16 positions yarn creel.

NOTE:

The picture may show fittings and equipment that are supplied on demand and not.

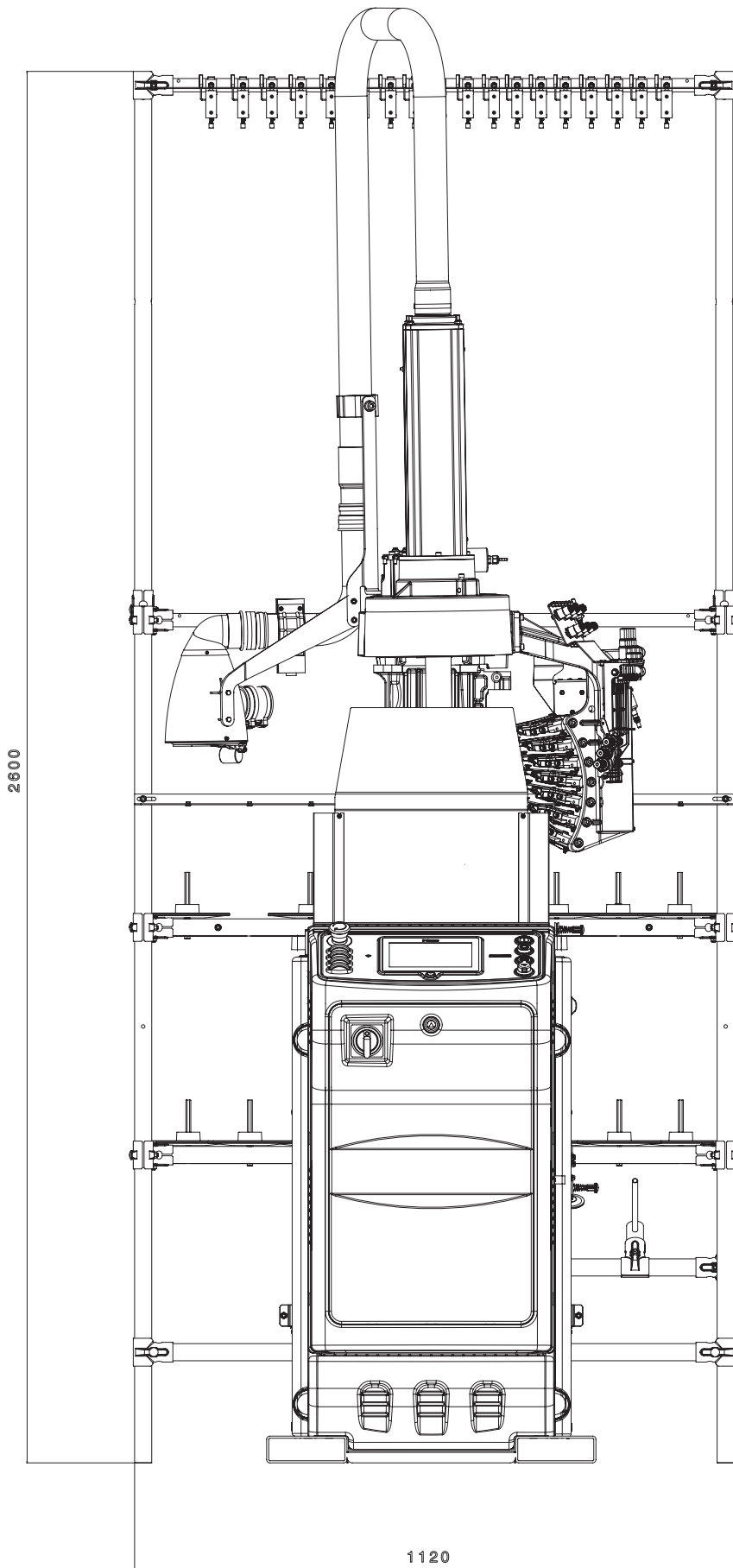

FRONT VIEW

Machine dimensions + 18 positions yarn creel.

NOTE:

The picture may show fittings and equipment that are supplied on demand and not.

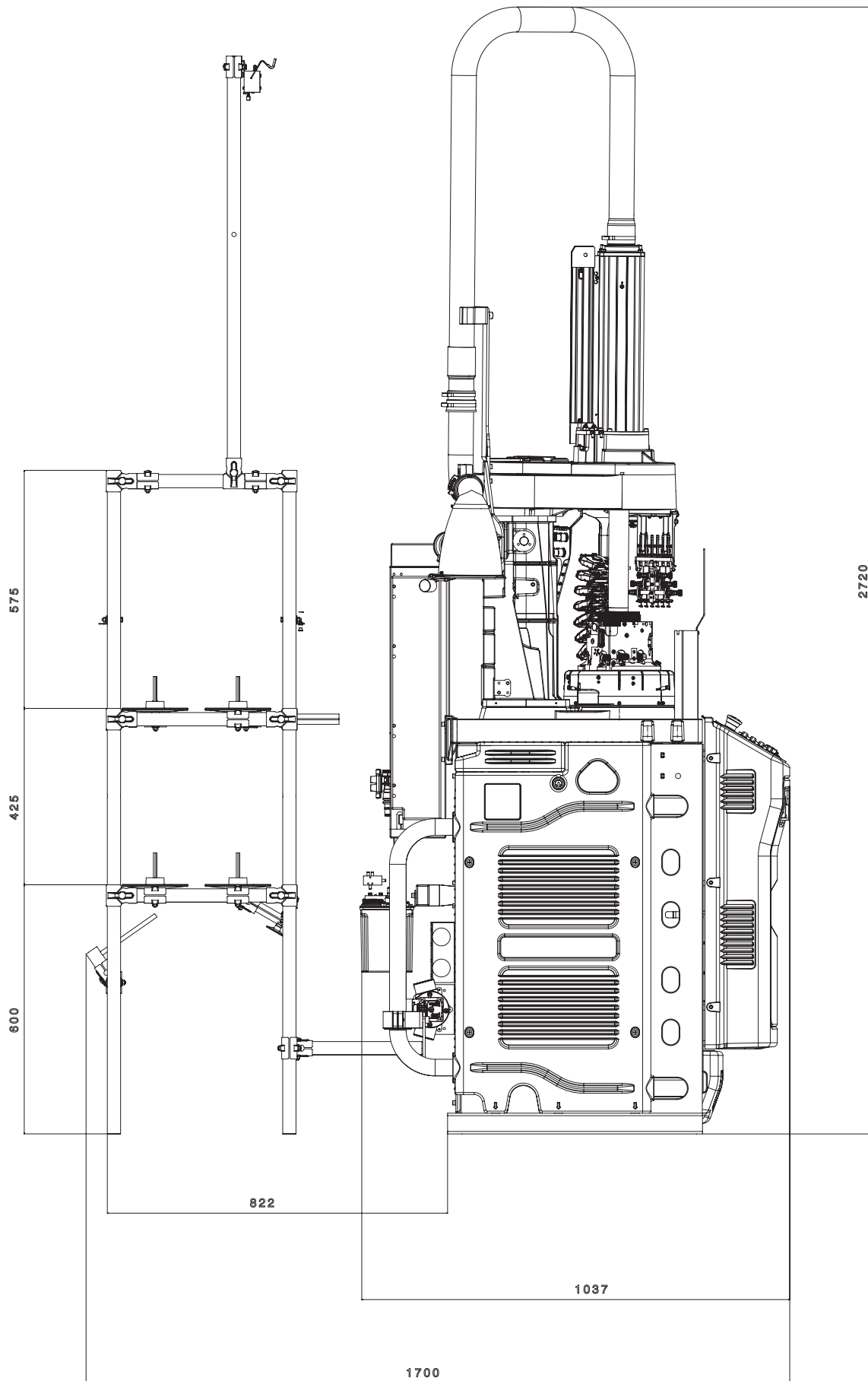

SIDE VIEW

Machine dimensions + 18 positions yarn creel.

NOTE:

The picture may show fittings and equipment that are supplied on demand and not.

NOTE

E1330X - E1430X - E1530X

NOTE

E1330X - E1430X - E1530X





LONATI SPA
Via Francesco Lonati, 3 | 25124 Brescia (Italy)
Tel. +39 03023901 | Fax +39 030 2310024
C.F.: 01469680175 | P.iva: 02096730961
info@lonati.com - www.lonati.com